

泉州豐群電子有限公司

C.C. FENG CHIUN ELECTRONIC CO., LTD.

OFFICE: TEL:+886-2-82522781
FAX:+886-2-82522782

FACTORY: TEL:+86-595-22632579
FAX:+86-595-22639258

1	MODEL	F36M89A(GP) (36CS04M-75BD9)
2	Dimension	Outer Diameter 36 mm Baffle Opening 32.5 mm.
		Height Refer to drawing Weight 7.8 Gram.
3	Magnet	Materials Rare Earth Size $\phi 12.5 \times 1.2$ mm.
4	Nominal Impedance	4 Ohm $\pm 15\%$
5	Power Rating	Normal 1.0 W. Maximum 2.0 W.
6	Lowest Resonant Frequency	560 \pm 112 Hz
7	Output Sound Pressure Level	85 \pm 3 dB / 1 Watt 1 Meter.
		Average at 600,800,1000,1200 HZ
8	Frequency Range	320~5500 Hz. Average SPL-10 dB.
9	Distortion	5 % Maximum At 1000 Hz 1.0 W.
10	Abnormal Sound Test	Must be Normally Tested By 2.0 Volts Sine Wave.
11	Load Test	White Noise with Weighted Filter 2.0 Volts. (RMS) 24 Hrs.
12	Operation Temperature	-25°C ~ +60°C
13	Storage Temperature	-40°C ~ +70°C
14	Polarity	Diaphragm shall move Forward when Apply a Positive DC
		Current to the "+" or "Marked" Terminal.
15	Remarks	Above specifications on the strength of CNS4784 and CNS4785.

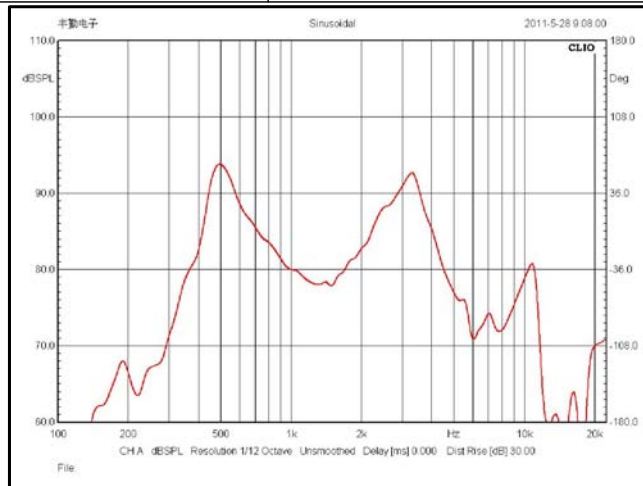

Bill of Material	
DIAPHRAGM	PET

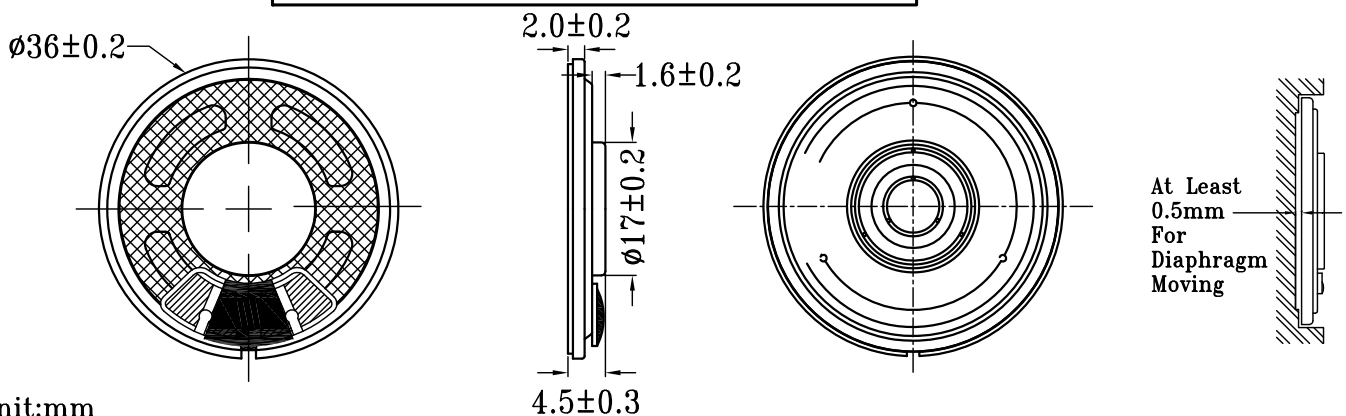

Unit:mm

Admitted:

Approved:

Made: